

APEX 1000

HIGH VELOCITY ALARM

TSS is proud to introduce Apex 1000 Velocity Alarm to the Critical Environments Industry. The Apex 1000 was developed by TSS to provide the industry with a cost-effective, accurate and reliable velocity alarm to help ensure a safe operating environment for laboratory personnel. The Apex 1000 is suited for use on all types of fume hoods and Biological Safety Cabinets.

- ▶ Simple to install and operate
- ▶ Continuous monitoring of Velocity
- ▶ Reliable, Accurate and Fast Speed of Response
- ▶ Night Set Back - Digital Input
- ▶ Alarm Status to BAS - Alarm Relay
- ▶ Visual Status Indicators
- ▶ Audible Alarm

(TSS Systems reserves the right to change information without notice.)

GENERAL DESCRIPTION

The Apex 1000 is installed directly onto the exterior of the device which it is monitoring - fume hood (FH) or biological safety cabinet (BSC). For FH applications, a small probe is provided which is to be installed on the interior sidewall of the hood. This probe is connected to the Apex 1000 using a very small (1/4" O.D.) tubing which is also provided. For BSC applications, a duct static pressure probe is used in lieu of the sidewall probe and is to be installed into the exhaust duct serving the BSC.

The Apex 1000 measures airflow by drawing an extremely small amount of air from the room through the front reference port (see front view drawing), through the internal air flow sensor and exits through the sidewall probe or static pressure probe. The airflow measured by the sensor is proportional to the FH face velocity and the BSC duct static pressure. If at any time the velocity drops below the calibrated alarm set point, the Apex 1000 goes into full alarm mode; audible alarm sounds, mute button is initialized, red LED flashes and the alarm relay changes state. The operator may silence the alarm by pressing the mute button; however the red LED and relay remain the same until the alarm condition has been cleared.

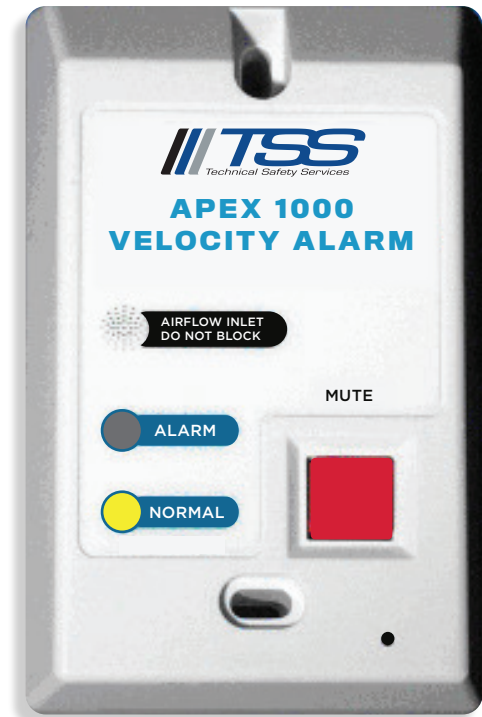

THEORY OF OPERATION

The Apex 1000 Velocity Alarm measures airflow velocity using an ultra-sensitive micro-bridge airflow sensor coupled with a high-resolution (24-bit) A/D converter. The resulting digital airflow measurement is extremely accurate, precise and repeatable. The alarm set point is programmed using a simple one-step operation which calibrates and stores data into the microprocessor's nonvolatile memory.

The microprocessor continually compares the real time measured airflow to the programmed alarm set point. When the measured airflow is greater than or equal to the calibrated alarm set point, the green LED is illuminated to indicate normal operating conditions. When the measured airflow is less than the calibrated alarm set point, the unit immediately goes into alarm mode alerting the lab occupants of a potentially unsafe condition. A mute button is provided to silence the audible alarm horn, while the red LED remains in a flashing state until the alarm condition has been cleared. The Apex 1000 also includes an alarm relay which can communicate the alarm status to the Building Automation System and a digital input which can be used to remotely mute the audible alarm.



620 Hearst Street
Berkeley, CA. 94710
800-877-7742

✉ info@techsafety.com 📶 techsafety.com ☎ 800-877-7742

APEX 1000

HIGH VELOCITY ALARM

- ▶ Elongated mounting holes to allow precise alignment
- ▶ Front surface is slightly tilted for easy viewing
- ▶ Status indicators are highly visible
- ▶ The air inlet port is built-in to the front surface, eliminating the need for external room reference probe
- ▶ The Mute button is large and easy to operate
- ▶ The alarm calibration button is concealed to prevent unauthorized calibration

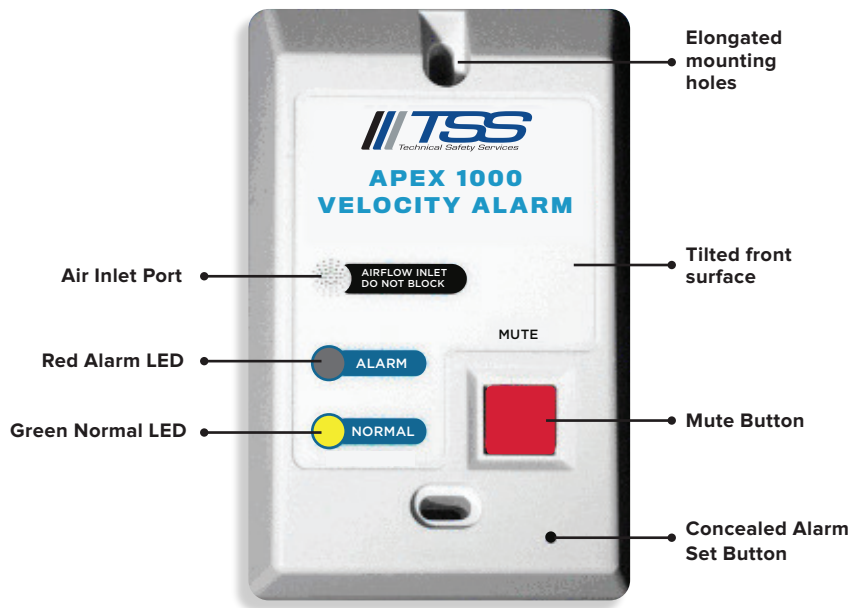

FRONT VIEW

- ▶ The recessed areas allow for mounting to almost any type of electrical box without encountering interference from the box. Also designed for surface mounting without using an electrical box.
- ▶ The hood reference probe is easily connected to airflow sensor port using ¼" tubing provided.
- ▶ The terminal strips are simple spring actuated press terminals for reliable electrical connections without having to loosen and tighten screws.
- ▶ Direct plug-in power connection to UL Listed Class II power supply provided with every alarm.

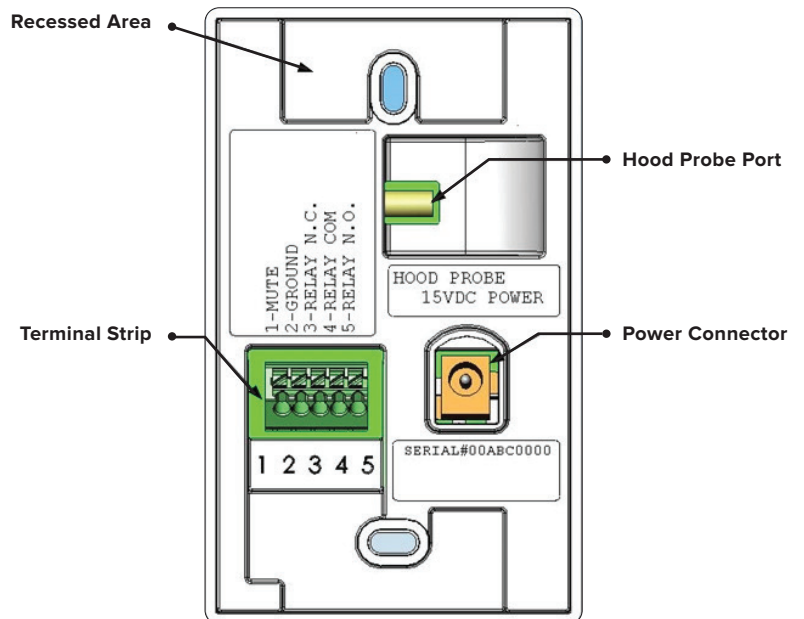

BACK VIEW

APEX 1000

HIGH VELOCITY ALARM

APEX 1000 SYSTEM COMPONENT CONNECTION

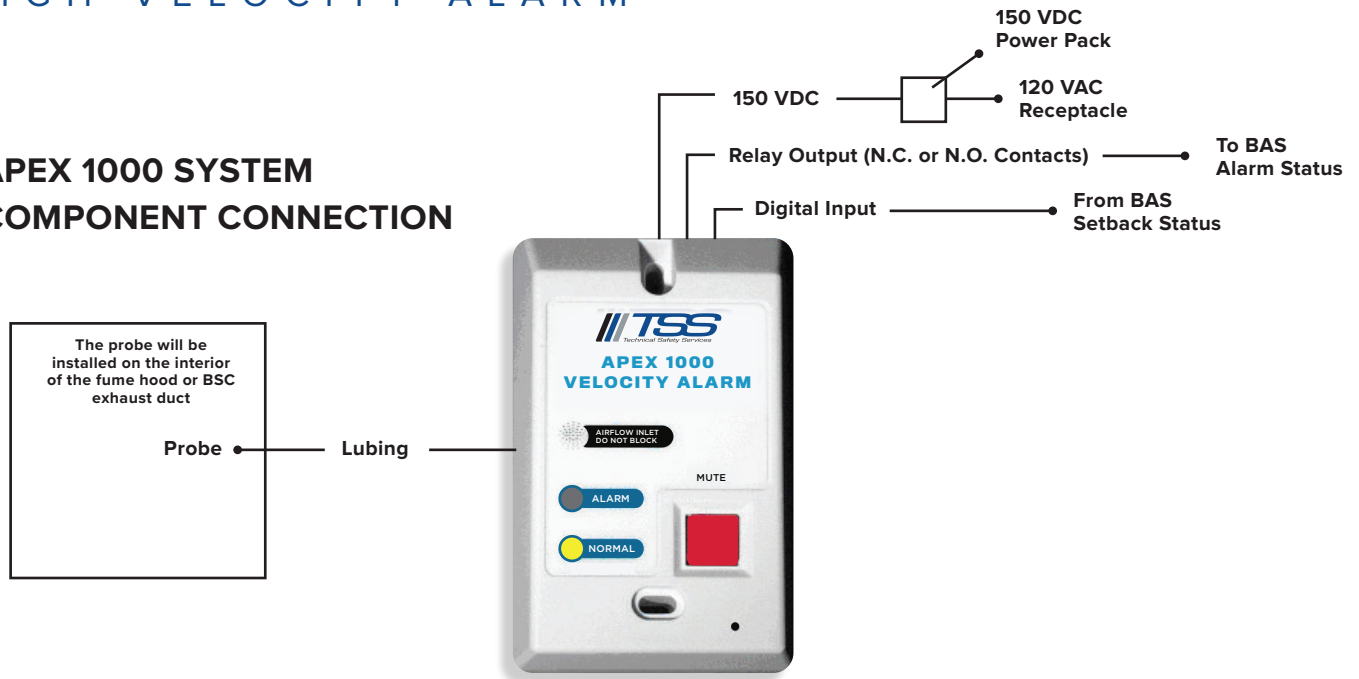

GENERAL SPECIFICATIONS

LED INDICATORS

Type: Ultra Bright clear lens

Green: Indicates normal condition

Red: Indicates alarm condition, flashes

AUDIBLE HORN

Sound Level: 90 dB at 10cm

Operation: Horn sounds during alarm condition

Re-beep Mode: (single fast tone every 2 minutes) Provides reminder horn muted and alarm not cleared

ALARM CONTACTS

Type: SPDT relay

Specifications: 1A @ 30 VDC, 0.5A @ 125 VAC (resistive load)

Operation: On alarm, N.O. contact closes and N.C. contact opens

DIGITAL INPUT

Type: Dry contact input

Operation: When digital input is grounded (via dry contact) audible

PUSH BUTTON

Mute: Silences horn, enables re-beep mode, resets automatically after alarm condition is cleared.

VELOCITY RANGE

30 – 2,000 FPM

ACCURACY

+/- 5% of set point

INPUT POWER

Voltage: 15VDC +/- 20% provided by class II UL approved wall

ENVIRONMENT

Temperature: Storage: 0°F to 150°F

Operating: 60°F to 80°F

Humidity: Storage: 10% to 90% RH, non-condensing

Operating: 20% RH to 90% RH, non-condensing

VELOCITY SENSOR

Type: Micro-bridge mass flow sensor

Overpressure: 25 PSI

REFERENCE PROBE

Internal: Integrated to display face, no external probe required

HOOD PROBE

Type: 7/16" diameter, feed through bushing, press fit, 5' tubing

Material: Polyethylene

Tubing Type: .170" ID ¼" OD Clear

Tubing Material: Ester based polyurethane

PHYSICAL CHARACTERISTICS

Size: 2.76" W x 4.5"H x 1.25"D

Weight: less than 5oz.

Materials: Enclosure Front & Back; White ABS Plastic



620 Hearst Street
Berkeley, CA. 94710
800-877-7742

APEX 1000

HIGH VELOCITY ALARM

MODEL NUMBER: T – ABVA

T-VBVA Model includes the following items:

- (1) Apex 1000 Velocity Alarm
- (1) Hood Probe with Tubing
- (2) 6-32 x 1.5" Mounting Screws
- (2) #6 x 1.5" Sheet Metal Screws (1) Reference Guide
- (1) Mounting Template
- (1) Wall Pluggable 15VDC Power Supply
- (2) Bushings for surface mounting

INSTALLATION

The ABVA can be mounted to a standard single gang electrical box using the included 6-32 machine screws. For instances where an electrical box is not available, the ABVA can be surface mounted by using the supplied hole template and drilling 5 holes (2 – 7/64" holes for supplied mounting sheet metal screws, 2- 11/16" holes for supplied bushings for tubing and wire and 1-1" hole for the power connector). **An additional 7/16" diameter hole is required for the mounting of the hood probe into the fume hood sidewall.**

PROGRAMMING THE ALARM SET POINT

Once all components are functioning (ex. hood controls, exhaust and supply fans, power, etc.) the ABVA can be commissioned. For fume hood applications; confirm the exhaust airflow volume is under accurate and stable control. Move the fume hood sash to the position that will achieve the desired face velocity alarm value and verify by traverse measurement. Press the concealed set button on the front of the ABVA using a paper clip (see front view description for location) and move away from the fume hood ABVA. The ABVA will chirp slowly 3 times, then fast 10 times then one long chirp. That's it! The first 3 chirps give the technician time to stand back from the ABVA, the next 10 chirps are actual sample readings the unit is gathering and the final long chirp tells the technician the ABVA is done. The entire commissioning process as described takes only 10 seconds! **To prevent unauthorized calibration, we recommend placing the calibration sticker over the alarm calibration hole.**



620 Hearst Street
Berkeley, CA. 94710
800-877-7742

✉ info@techsafety.com 📶 techsafety.com ☎ 800-877-7742